

AES/EBU DA with Analogue Monitoring

FEATURES

- 2 balanced AES, 2 unbalanced AES and 2 analogue stereo outputs.
- 24 bit digital to analogue processing.
- 75 and 110 Ohm inputs.
- Front panel digital monitoring output.
- Front panel audio level and AES error indications.
- All inputs and outputs transformer coupled.
- Digital circuit re-shapes output and restores level.
- No cable compensation adjustments required.
- Optional plug-in SNMP monitoring module.

GENERAL

The DAC-4412 is designed to provide AES/EBU digital audio conversion to analogue stereo format. Four AES outputs (two balanced 110 Ohm and two unbalanced 75 Ohm) are provided for through signal and monitoring purposes.

The DAC-4412 may be used with AES digital signals at 48 kHz.

The digital circuitry of the DAC-4412 restores the signal rise and fall times and output level without the need to manually adjust gain and compensation controls.

The digital converter monitors the AES signal for errors, and lights an alarm indication on the front panel.

LEDs are also provided to indicate the analogue output level. These are user adjustable, but factory set to a -40 dBFS threshold.

Link settings allow the analogue audio output to be muted on loss of digital input.

An optional SNMP (Simple Network Management Protocol) plug-in module is available for remote monitoring when used in conjunction with IRT's frame fitted with SNMP capability.

The DAC-4412 is designed to fit IRT's standard Eurocard frames and may be used alongside any other of IRT's analogue or digital Eurocards.

BLOCK DIAGRAM DAC-4412 SIGNAL PATH

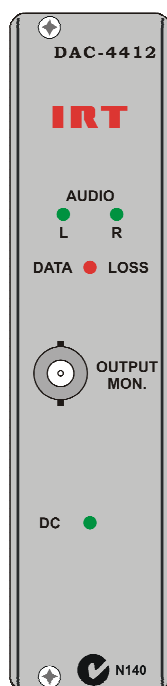
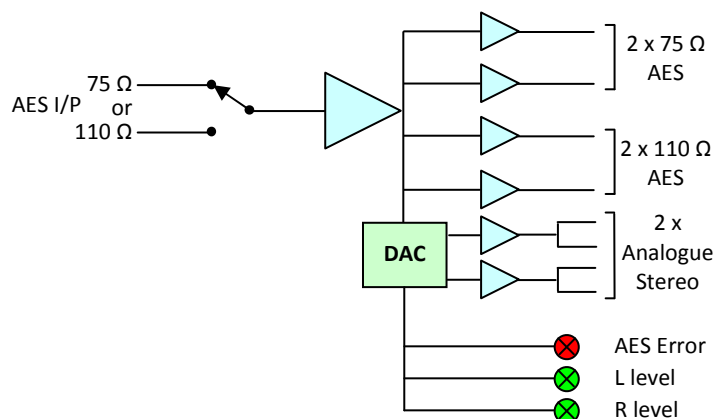

TECHNICAL SPECIFICATIONS

Inputs:

Number	2.
Type	1 x 110 Ω balanced, or 1 x 75 Ω unbalanced, selected by link on PCB.
Format	AES3-1992 standard.
Input level	200 mVp-p minimum.
Cable length	> 500 m 75 Ω (Belden 8281), > 200 m 110 Ω (AES digital high quality shielded pair).

Outputs - Digital:

Number	4.
Type	2 x 75 Ω unbalanced > 1 Vp-p, and 2 x 110 Ω balanced > 3 Vp-p.
Monitoring	1 x 75 Ω unbalanced.
Format	AES3-1992 standard.

Outputs - Analogue:

Number	2 stereo, mutable by link settings on loss of input.
Type	40 Ω balanced.

Performance:

Frequency	48 kHz.
Rise & fall times	< 20 ns.
Level for full code	+24 dBu (variable by internal factory preset).
Frequency response	\pm 0.1 dB 50 Hz to 15 kHz; \pm 0.2 dB 15 kHz to 20 kHz.
THD+N	< 0.025%.
Noise	-100 dBFS ('A' weighted with idle channel, digital input all zeros).
Linearity	< \pm 0.5 dB at -90 dBFS.
De-emphasis	Automatic from channel status.
Mute level	60dB down from peak output.

Power requirements:

Voltage	28 Vac CT (14-0-14) or \pm 16 Vdc.
Power consumption	< 6 VA.

Connectors:

Balanced	Phoenix 3 terminal plug-in blocks.
Unbalanced	BNC.

Other:

Temperature range	0 - 50° C ambient.
Mechanical	Suitable for mounting in IRT 19" rack chassis with input, output and power connections on the rear panel.
Finish	Front panel Grey background, black lettering & red IRT logo. Rear assembly Detachable silk-screened PCB with direct mount connectors to Eurocard and external signals.
Dimensions	6 HP x 3 U x 220 mm IRT Eurocard.
Supplied accessories	Rear connector assembly including matching plugs for balanced connections.
Optional accessories	SMU-4000 plug in SNMP Management Information Base (MIB) module.