



IRT Electronics Pty Ltd A.B.N. 35 000 832 575
26 Hotham Parade, ARTARMON N.S.W. 2064 AUSTRALIA
National: Phone: (02) 9439 3744 Fax: (02) 9439 7439
International: +61 2 9439 3744 +61 2 9439 7439
Email: sales@irtelectronics.com
Web: www.irtelectronics.com

IRT Eurocard
Type DDC-3340
SPI to ASI Converter

Designed and manufactured in Australia

IRT can be found on the Internet at:
<http://www.irtelectronics.com>

IRT Eurocard

Types DDC-3340

SPI to ASI Converter

Instruction Book

Table of Contents

| Section | Page |
|---------------------------------------|------|
| Operational Safety | 2 |
| General description | 3 |
| Technical specifications | 4 |
| Technical description | 5 |
| Internal adjustments | 6 |
| Configuration | 6 |
| Installation | 6 |
| Connections - ASI & SPI | 7 |
| ASI | 7 |
| SPI | 7 |
| Front & rear panel connector diagrams | 8 |
| Maintenance & storage | 9 |
| Warranty & service | 9 |
| Equipment return | 9 |
| Drawing index | 10 |

This instruction book applies to units later than S/N 9907000.

Operational Safety:

WARNING

Operation of electronic equipment involves the use of voltages and currents that may be dangerous to human life. Note that under certain conditions dangerous potentials may exist in some circuits when power controls are in the **OFF** position. Maintenance personnel should observe all safety regulations.

Do not make any adjustments inside equipment with power **ON** unless proper precautions are observed. All internal adjustments should only be made by suitably qualified personnel. All operational adjustments are available externally without the need for removing covers or use of extender cards.

General description

The DDC-3340 series is part of a family of data transcoders for converting between the MPEG2 Transport Stream formats commonly used in the broadcast industry for program distribution.

Equipment is built to perform a specific task and is provided with inputs and outputs suitable to performing that task. As systems are built from individual pieces of equipment the need arises to provide interfaces between the various formats. The DDC-3330 provides conversion from ASI to SPI and conversely, the DDC-3340 provides conversion from SPI to ASI.

ASI:

ASI MPEG data is transported in a 270 Mb/s signal regardless of the underlying data rate. It is a convenient and relatively inexpensive way of transporting data. ASI signals may be transported over good quality 75 Ohm coaxial cable for distances of up to 300 m, but it is recommended that in actual practice cable lengths be kept to less than 100 m.

Where greater distances are involved, distribution amplifiers may be used to re-equalise the signal at intervals along the path.

Alternatively, consideration should be given to using the IRT DVT-3210 / DVR-3210 fibre optic link, which will transport ASI signals over single mode fibre optic cable for distances up to 60 Km (dependent on fibre losses).

SPI:

The SPI interface is a ten bit wide parallel interface with a synchronous clock signal. Each of the eleven signals is sent using LVDS drivers (Low Voltage Differential Signalling). This results in a word (or byte) parallel signal at less than a 1/10th the bit rate of ASI, making it ideal for processing, but is not suitable for use with anything other than very short cable connections. For practical purposes 5 metres is suggested as a maximum. Where longer distances are involved, the SPI signal should be converted to ASI and run using coaxial cable or fibre links.

The DDC-3340 module should therefore be located as close as possible to the connected SPI equipment, rather than the ASI equipment.

The DDC-3340 does not perform any signal correction or alter the format of the MPEG2 transport stream. It only - serialises the SPI input and monitors the signal for MPEG2 transport stream sync errors.

Standard features:

- **Transparent SPI to ASI conversion.**
- **One module covers data rates from 1.5 Mb/s to 50 Mb/s.**
- **Block length indication (188/204).**

Related equipment:-

FRU-3000 Eurocard module mounting frame

Mounts up to 12 Eurocard modules and one PT-700 Dual AC power supply side by side in 134 mm of standard rack space (3 Rack Units).

FRU-1030 1 RU chassis conversion/PSU

Converts Eurocards to a 1 rack unit format. The FRU-1030 can be fitted with either one or two Eurocards in a horizontal side by side format. A single AC power supply is included to power the cards.

TME-6 Eurocard extender board.

Technical specifications
IRT Eurocard module
Type DDC-3340

MPEG:

Input:

| | |
|----------------|---|
| Type | 1 x SPI (EN50083-9) |
| MPEG data rate | From 2 to 50 Mb/s. |
| Connector | 25 pin 'D' female.(to EN50083-9 Table 1) |

Outputs:

| | |
|------------------|------------------------|
| Type | 1 x ASI-C (EN50083-9). |
| Output impedance | 75Ω. |
| Signal level | 800 mVp-p. |
| Connector | BNC. |

Indicators:

| | |
|-------|-----------------------|
| Power | LED (Green) for +5 V. |
| Input | LED (Red). |
| Sync | LED (Red). |
| 188 | LED (Green). |
| 204 | LED (Green). |

| | |
|--------------------|----------------------------------|
| Power Requirements | 28 Vac CT (14-0-14) or ± 16 Vdc. |
| Power consumption | <4 VA. |

Other:

| | |
|----------------------|---|
| Temperature range | 0 - 50° C ambient |
| Mechanical | Mounts in IRT FRU-1030 19" 1 RU frame with input and output connections on the rear panel. |
| Finish: | Front panel Grey enamel, silk-screened black lettering & red IRT logo |
| | Rear assembly Detachable silk-screened PCB with direct mount connectors to Eurocard and external signals |
| Dimensions | 6 HP x 3 U x 220 mm IRT Eurocard |
| Supplied accessories | Rear connector assembly including matching connector for alarm output. |
| Related products | DDC-3330 – ASI to SPI 1.5 to 50 Mb/s DDC-3460 - G.703 to SPI & ASI. DDC-3470 - SPI to G.703 & ASI with encode & decode processing. DDC-3475 - SPI to G.703 & ASI without processing. |

Technical description

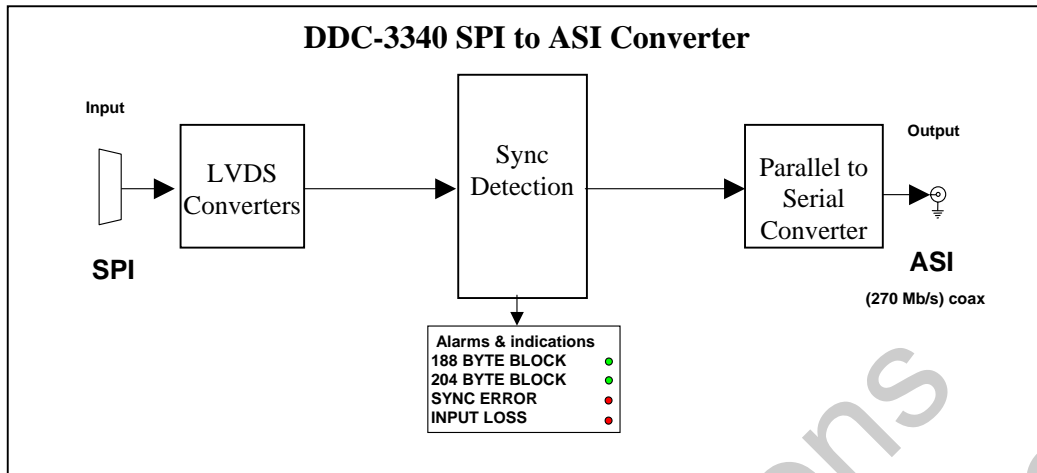

LED Indicators.

| | |
|-------|--|
| INPUT | Illuminates red if the input clock is missing. |
| SYNC | Reserved. |
| 188 | Indicates that the input stream is has 188 bytes per packet. |
| 204 | Indicates that the input stream is has 204 bytes per packet |

Data Valid (D_val).

D_val as an input is not used in the DDC-3340.

SPI connectors:

The SPI uses 25 pin 'D' connectors. Cable connectors are male and equipment connectors are female. Interconnecting cables and connectors must be shielded. Logic levels are LVDS.

| Pin | Signal line | Pin | Signal line |
|-----|---------------|-----|-------------|
| 1 | Clock A | 14 | Clock B |
| 2 | System Gnd | 15 | System Gnd |
| 3 | Data 7 A(MSB) | 16 | Data 7 B |
| 4 | Data 6 A | 17 | Data 6 B |
| 5 | Data 5 A | 18 | Data 5 B |
| 6 | Data 4 A | 19 | Data 4 B |
| 7 | Data 3 A | 20 | Data 3 B |
| 8 | Data 2 A | 21 | Data 2 B |
| 9 | Data 1 A | 22 | Data 1 B |
| 10 | Data 0 A | 23 | Data 0 B |
| 11 | DVALID A | 24 | DVALID B |
| 12 | PSYNC A | 25 | PSYNC B |
| 13 | Cable Shield | | |

Internal adjustments

There are no internal adjustments.

Configuration

The DDC-3340 has no user configurable adjustments.

Installation

Operational Safety:

WARNING

Operation of electronic equipment involves the use of voltages and currents that may be dangerous to human life. Note that under certain conditions dangerous potentials may exist in some circuits when power controls are in the **OFF** position. Maintenance personnel should observe all safety regulations.

Do not make any adjustments inside equipment with power **ON** unless proper precautions are observed. All internal adjustments should only be made by suitably qualified personnel. All operational adjustments are available externally without the need for removing covers or use of extender cards.

Pre-installation:

Handling:

This equipment may contain or be connected to static sensitive devices and proper static free handling precautions should be observed.

Where individual circuit cards are stored, they should be placed in antistatic bags. Proper antistatic procedures should be followed when inserting or removing cards from these bags.

Power:

AC mains supply: Ensure that operating voltage of unit and local supply voltage match and that correct rating fuse is installed for local supply.

DC supply: Ensure that the correct polarity is observed and that DC supply voltage is maintained within the operating range specified.

Earthing:

The earth path is dependent on the type of frame selected. In every case particular care should be taken to ensure that the frame is connected to earth for safety reasons. See frame manual for details.

Signal earth: For safety reasons a connection is made between signal earth and chassis earth. No attempt should be made to break this connection.

Installation in frame or chassis:

See details in separate manual for selected frame type.

Connections:

ASI:

ASI MPEG data is transported in a 270 Mb/s signal regardless of the underlying data rate. Therefore, all cabling and connectors should be of high quality and have a true 75 Ohm characteristic impedance.

ASI signals may be transported over good quality 75 Ohm coaxial cable for distances of up to 300 m, but again it is recommended that in actual practice cable lengths be kept to less than 100 m.

Where greater distances are involved, distribution amplifiers may be used to re-equalise the signal at intervals along the path.

Alternatively, consideration should be given to using the IRT DVT-3210 / DVR-3210 fibre optic link, which will transport ASI signals over single mode fibre optic cable for distances up to 60 Km (dependent on fibre losses).

Electrical characteristics ASI:

Transmitter output characteristics:

| | |
|-------------------------|----------------------|
| Output voltage | 800 mVp-p \pm 10%. |
| Deterministic jitter | <10% p-p. |
| Random jitter | <8% p-p. |
| Rise/fall time (20-80%) | <1.2 ns. |

Receiver input characteristics:

| | |
|--|-------------------------|
| Minimum sensitivity (D21.5 idle pattern) | 200 mV |
| Maximum input voltage | 880 mVp-p |
| s_{11} (range: 0.1 to 1.0 x bit rate) | -17 dB |
| Minimum discrete connector return loss | 15 dB (5 MHz - 270 MHz) |

Coaxial link:

| | |
|---------------------|-------------|
| Impedance | 75 Ohm. |
| Equipment connector | BNC female. |

(Electrical measurements made with 75 Ohm resistive termination.)

SPI:

The SPI interface is a ten bit wide parallel interface with a synchronous clock signal. Each signal is sent using LVDS drivers (Low Voltage Differential Signalling).

This means that a balanced pair is required for each signal, entailing a total of twenty two signal wires plus at least one ground connection. A twenty five pin 'D' connector is standard for this system.

The SPI interface is not suitable for use with anything other than very short cable connections. For practical purposes 5 metres is suggested as a maximum. Where longer distances are involved, the SPI signal should be converted to ASI and run using coaxial cable or fibre links.

The DDC-3330 module should therefore be located as close as possible to the connected SPI equipment, rather than the ASI equipment.

Good quality cable and connectors must be used. For EMC it is necessary to use only 'D' connectors with full metal shells and the cable outer screen should be properly connected to the shell. Unshielded cables must not be used at all.

The 'D' connectors should have their securing screws firmly screwed down to ensure a continuous earth shroud is maintained. These screws are not simply to ensure that the connector does not become unplugged, they are an integral part of the EMC screening and signal connection.

Electrical characteristics SPI:

Line Driver Characteristics (Source)

| | |
|---------------------|---|
| Output impedance | 100 Ω maximum |
| Common mode voltage | 1.125 V to 1.375 V |
| Signal amplitude | 247 mV to 454 mV |
| Rise and fall times | < T/7, measured between the 20% and 80% amplitude points, with a 100 Ω resistive load. The difference between rise and fall times shall not exceed T/20. |

Line Receiver Characteristics (Destination)

| | |
|----------------------|-----------------------------|
| Input impedance | 90 Ω to 132 Ω |
| Maximum input signal | 2.0 Vp-p |
| Minimum input signal | 100 mVp-p |

Front & rear panel connector diagrams

The following front panel and rear assembly drawings are not to scale and are intended to show relative positions of connectors, indicators and controls only.

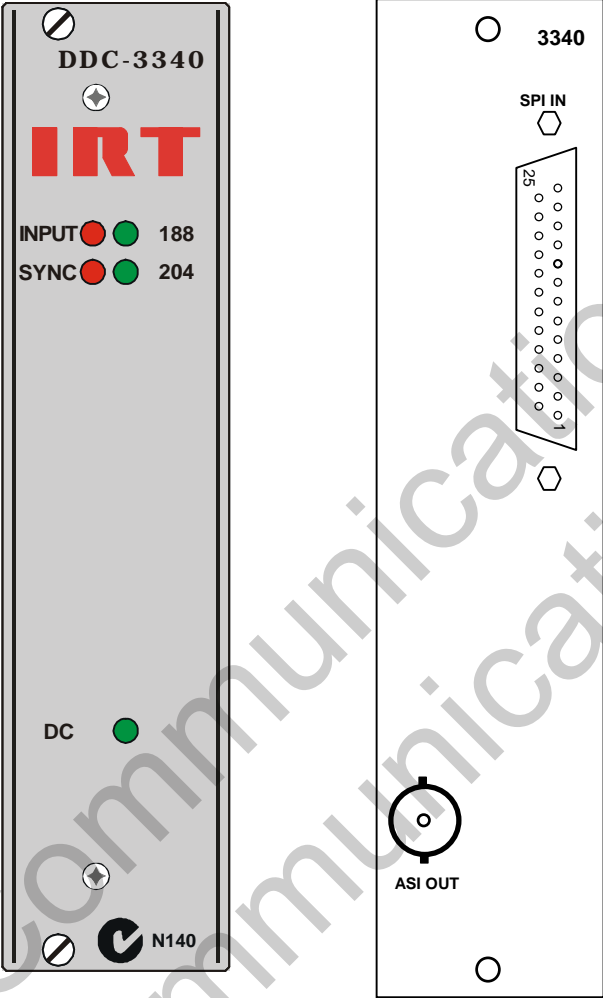

Maintenance & storage

Maintenance:

No regular maintenance is required.

Care however should be taken to ensure that all connectors are kept clean and free from contamination of any kind. This is especially important in fibre optic equipment where cleanliness of optical connections is critical to performance.

Storage:

If the equipment is not to be used for an extended period, it is recommended the whole unit be placed in a sealed plastic bag to prevent dust contamination. In areas of high humidity a suitably sized bag of silica gel should be included to deter corrosion.

Where individual circuit cards are stored, they should be placed in antistatic bags. Proper antistatic procedures should be followed when inserting or removing cards from these bags.

Warranty & Service

Equipment is covered by a limited warranty period of three years from date of first delivery unless contrary conditions apply under a particular contract of supply. For situations when “**No Fault Found**” for repairs, a minimum charge of 1 hour’s labour, at IRT’s current labour charge rate, will apply, whether the equipment is within the warranty period or not.

Equipment warranty is limited to faults attributable to defects in original design or manufacture. Warranty on components shall be extended by IRT only to the extent obtainable from the component supplier.

Equipment return:

Before arranging service, ensure that the fault is in the unit to be serviced and not in associated equipment. If possible, confirm this by substitution.

Before returning equipment contact should be made with IRT or your local agent to determine whether the equipment can be serviced in the field or should be returned for repair.

The equipment should be properly packed for return observing antistatic procedures.

The following information should accompany the unit to be returned:

1. A fault report should be included indicating the nature of the fault
2. The operating conditions under which the fault initially occurred.
3. Any additional information, which may be of assistance in fault location and remedy.
4. A contact name and telephone and fax numbers.
5. Details of payment method for items not covered by warranty.
6. Full return address.
7. For situations when “**No Fault Found**” for repairs, a minimum charge of 1 hour’s labour will apply, whether the equipment is within the warranty period or not. Contact IRT for current hourly rate.

Please note that all freight charges are the responsibility of the customer.

The equipment should be returned **to the agent who originally supplied the equipment** or, where this is not possible, to IRT direct as follows.

Equipment Service
IRT Electronics Pty Ltd
26 Hotham Parade
ARTARMON
N.S.W. 2064
AUSTRALIA

Phone: 61 2 9439 3744

Fax: 61 2 9439 7439

Email: service@irtelectronics.com

Drawing index

| Drawing # | Sheet # | Description |
|-----------|---------|------------------------------------|
| 804356 | 1 | DDC-3340 signal processing diagram |

IRT Communications
www.irtcommunications.com

